

Stereo 80

Vacuum Tube Amplifier

Owner's Manual

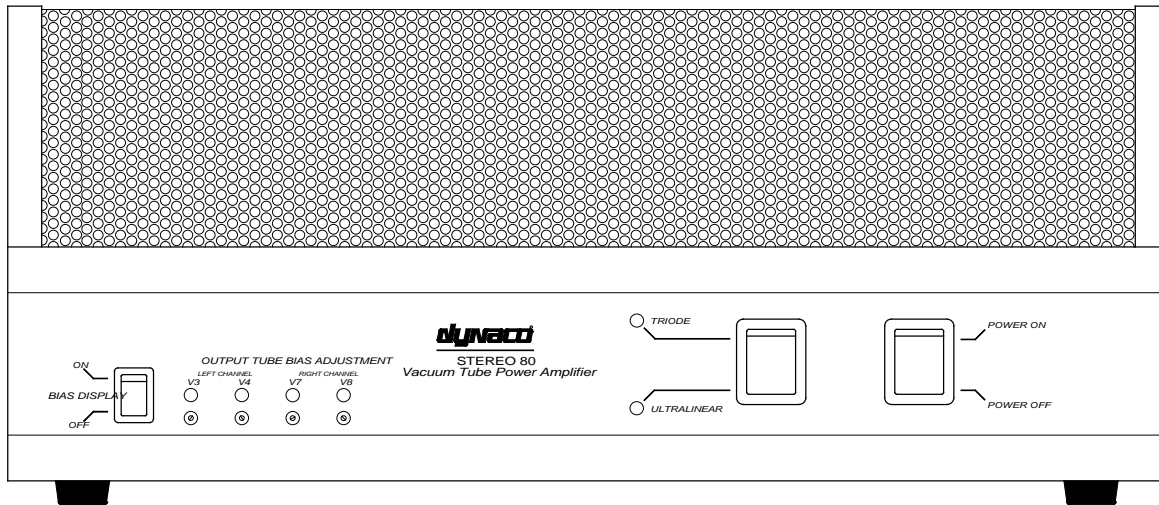

Stereo 80 Vacuum Tube Power Amplifier

Contents

Introduction	3
Vacuum Tube Warm Up	4
Rear Panel Inputs and Outputs	4
Input Sensitivity Setting	5
Power On/Off Indicators and Fuses	6
Triode/Ultralinear Modes	7
Bias Adjustments - general	8
Output Tube Bias Adjustment Procedure	9
Burn-In Procedure for New Output Tubes	10
Tube Replacement	11
Alternate Tube Types	13
Minimizing Noise in the System	14
Warranty	15
Stereo 80 Specifications	16
Schematics	17
Stereo 80 PC Board Parts List	20

Please read this manual thoroughly before operating your new Stereo 80.

Introduction

Congratulations on your purchase of the Dynaco Stereo 80 Amplifier. This product was designed to provide the highest combination of quality and value available, which is the Dynaco tradition.

The Dynaco Stereo 80 amplifier uses special power supply buffering circuitry - found in no other brand of amplifiers in this class. We have included a separate buffer circuit for each of the input and driver tubes in the Stereo 80, allowing each amplification stage to function more independently, (as if each one had its own separate power supply). This method contributes significantly to the sonic clarity of the Stereo 80.

The Stereo 80 can be operated in either Triode or Ultralinear mode. Switching between the two is easily done via a front panel switch.

State-of-the-art biasing circuitry allows you to easily attain precision bias settings for each of the output tubes through front panel adjustments and indicators.

Another special feature of the Stereo 80 is its adjustable Input Sensitivity. This allows the Stereo 80 to be connected directly to components having vastly different output signal levels. The user can, for example, connect a CD player directly to the Stereo 80 *without using a preamplifier*.

You will find the Stereo 80 *sounds* better than the large majority of other amplifiers - both solid state *and* vacuum tube designs - regardless of price. Your Stereo 80 was designed and built entirely in the USA. We are proud to offer this outstanding amplifier to discerning audiophiles the world over.

Dynaco Engineering Group

Vacuum Tube Warm-Up

Although a vacuum tube power amplifier begins to work in as little as 15 seconds after being switched on, it is important to allow a 3 minute warm-up period before using the amplifier.

Output tubes can be slightly damaged each time they are forced into use before being warmed-up, resulting in non-optimum sound and shorter tube life. If one listens to music during the warm-up period, one may notice that the output volume of the amplifier changes as the tubes warm up.

We recommend that you wait at least 3 minutes after switching the amplifier on before using it. On the Stereo 80, waiting about one minute after the four bias lamps turn from “green” to “off” is a proper (minimum) warm-up period. (See section entitled **Bias Adjustments - general**)

Rear Panel Inputs and Outputs

Inputs

There are two input jacks located on the rear panel of the amplifier - labeled Left and Right. These connect to your preamplifier Line Outputs.

Never plug in, or disconnect, interconnect cables from other components to the amplifier when it is turned on. To do so could cause a fuse to blow or even damage the speakers.

Outputs

Match the impedance of your speakers to the amplifier by connecting the positive (+) speaker wire of each channel to its corresponding 2 ohm, 4 ohm, or 8 ohm red binding post. Connect the negative (-) speaker wire from each channel to its corresponding black binding post.

You can safely connect or disconnect speaker cables to/from the amplifier while it is turned on. It is best at those times to turn down volume control(s) on any equipment connected to the amplifier inputs. (Nevertheless, care should be taken to not touch bare speaker wires together if one end of the speaker cable is connected to the amplifier.)

Input Sensitivity Setting

The Input Sensitivity adjustment is located on the rear panel, to the right of the input RCA jacks. This feature allows you to select how large of an input signal will result in full power output of the amplifier.

The Input Sensitivity adjustment can be used to “match” the Stereo 80 inputs to your preamplifier outputs. You can set it so that the preamplifier volume control can be turned all the way up before clipping occurs in the Stereo 80. This also allows you to connect audio components, such as CD players, directly to the Stereo 80 without using a preamplifier, if desired.

Most power amplifiers have input sensitivities in the range of 1 to 1.5 volts. If an amplifier has an input sensitivity of 1 volt, this means that an input signal level of 1 volt will produce the full rated output power of the amplifier.

The Input Sensitivity on the Stereo 80 can be adjusted as follows:

- Set at *Normal* (12 o'clock) the input sensitivity is approximately 1.5V.
- Set at *Low* (9 o'clock) the input sensitivity is approximately 5.5V.
- Set at *High* (3 o'clock) the input sensitivity is approximately .5V.
- Set fully clockwise, the input sensitivity is under .3V.

Power On/Off Indicators and Fuse

The Stereo 80 Power On/Off indicator is either the Ultralinear (red) lamp or the Triode (amber) lamp. The lamp which is lit when the Power On/Off switch is turned on will depend upon the Triode/Ultralinear switch position.

During the first minute or so after the Stereo 80 is first switched on, all four output tube bias indicator lamps glow green. As the unit warms up, these lamps should go off, indicating the unit is ready for use.

If the bias indicator lamps remain green (or turn red) after the initial warm-up period, a low or high AC line voltage condition may be indicated. The AC line voltage varies from country to country, city to city, house to house, and even the time of day in many locations. It can also be affected by common appliances such as electric heaters, microwave ovens, clothes dryers, etc. Therefore, you may need to set the output tube bias adjustments to suit your own location. (See section entitled **Bias Adjustments - general.**)

Fuses

AC Line Fuse (F1):

7 Amp Fast-Blow - 100 or 120VAC
3.5 Amp Fast-Blow - 220 or 240VAC

To remove the AC line fuse, use a small screwdriver to push forward the tab near the center of the Power Entry Module.

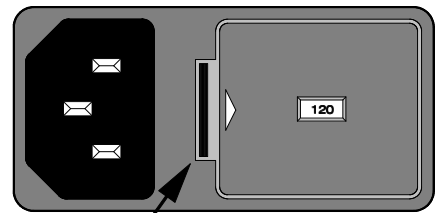

PUSH TAB TO RELEASE FUSE HOLDER

Always remove the power cord when accessing the AC line fuse.

Triode/Ultralinear Modes

The Ultralinear mode is usually considered to be the “normal” mode of operation. The overall power rating of the amplifier is specified for Ultralinear mode.

In Ultralinear mode, the screen grid of each output tube is connected to a tap on its associated output transformer. When Triode mode is selected, the screen grids are (instead) connected to the plates of their respective output tubes.

Operating the amplifier in Triode mode reduces the amplifier output power to about 1/2 of that in Ultralinear mode. Triode mode also softens the clipping characteristics of the amplifier so it seems to need less output power. Triode mode produces more lower-even order harmonics, whereas Ultralinear mode produces higher-odd order harmonics.

Some people prefer Triode mode; some people prefer Ultralinear mode. The choice of which mode to use is also often influenced by the sonic characteristics of the speakers being used.

You can listen and compare to determine which mode sounds best to you for your chosen music material and speakers.

Bias Adjustments - general

The Stereo 80 incorporates integrated circuits that monitor the actual quiescent (idle) current of each output tube. For each output tube there is a separate bias adjustment potentiometer accessible from the front panel of the amplifier. Directly above each adjustment potentiometer is the indicator lamp for the tube which it adjusts.

The front panel switch labeled Bias Display On/Off must be *ON* for bias adjustments. The Bias Display On/Off switch (optionally) can be left on while listening to music. If it is left on there will be a “light-show” display effect which varies with the music material.

During bias adjustments each indicator lamp shows three different conditions. When it glows green it means that the bias is set too low for the output tube. When it glows red it means that the bias is set too high. When the lamp is not lit (neither green nor red) it means that the bias setting is correct and is in the range of 74 to 87 millivolts, (measured across each 2 ohm output tube current sensing resistor - R20, 21, 120, or 121). The correct bias current setting for the EL34 output tubes used with the Stereo 80 is: 40ma +/- 5ma

Before bias adjustments are made, the amplifier must be fully warmed up. As a minimum requirement, the amplifier should be turned on for 15 minutes prior to bias adjustments. Letting it idle for a full hour so that all components come up to full thermal equalization is also a good idea, but not usually required.

Notes: For newly installed output tubes, the first three hours is the “burn-in” period. During this time bias settings need to be closely monitored because they go higher (by themselves) while the tubes burn-in. If a tube is operated with its bias setting a lot higher than it should be, the tube could actually burn out or cause other amplifier components to fail.

The output tubes in your new Stereo 80 have already been burned-in and properly biased at the factory. Nevertheless, when you first start using your amplifier you should check the bias settings using the Output Tube Bias Adjustment Procedure on the following page.

As mentioned earlier, AC line voltage levels can vary greatly. Even after proper output tube bias adjustments are completed on your amplifier, temporary changes in the AC line voltage can make it seem that the bias settings are not correct. If the AC line voltage is low, one or more of the bias indicator lamps may continue to glow green after the initial one-minute warm-up period. Likewise, if one or more of the bias indicator lamps glows red after the initial warm-up period, a high AC line voltage condition may be indicated. *If a low or high AC line voltage condition is only temporary, you do not need to re-adjust the bias settings..*

Output Tube Bias Adjustment Procedure

- 1) Warm up amplifier for 15 minutes (or more).
- 2) Turn off any equipment connected to the amplifier inputs and ensure that the Bias Display On/Off switch is *ON*.
- 3) Using the adjustment tool provided with the amplifier, adjust each 25-turn trimmer potentiometer to a point where its lamp does not glow. (This point should be midway between red and green.)

Counter-clockwise rotation turns the bias down, “towards green”.

Clockwise rotation turns the bias up, “towards red”.

Notes: If the lamp is glowing red it means that the bias is set too high. Do not turn the adjustment potentiometer further clockwise as this makes the bias setting even higher.

If an output tube bias indicator lamp cannot be adjusted for both green and red, the associated output tube is probably faulty.

Adjusting the potentiometer for one lamp can seem to affect the lamps of the other tubes as well. This is normal. Allow each change to *settle* for a second or two before going on to the next trimmer potentiometer. Repeat the adjustments as necessary.

Bias adjustments will be needed less often as the output tubes age.

Bias adjustments can be made at any time while using the amplifier - as long as the amplifier is warmed up.

If the Bias Display On/Off switch is left on, one can easily check the bias settings at a glance. This could be whenever the amp is not receiving input signals (such as during the blank time between tracks on a CD or record).

Burn-In Procedure for New Output Tubes

Note: This procedure applies *only* when you have installed new output tubes which have not yet been burned-in. (The tubes installed on your new Stereo 80 have already been burned-in at the factory.) Also see section entitled: **Tube Replacement**.

- 1) Turn off any equipment connected to the amplifier inputs.
- 2) Turn the bias adjust potentiometer for each newly installed tube fully counter-clockwise. This can take as many as 30 turns. A faint “clicking” sound, which is not harmful, may be heard if you continue to turn the potentiometer beyond its fully counter-clockwise position. (Use the adjustment tool provided with the amplifier.)
- 3) Switch the amplifier on and allow it to warm up 5 to 10 minutes. Ensure that the Bias Display On/Off switch is set to *ON*. Note that all bias indicator lamps adjusted in 2) glow green. If any bias adjustment lamp is not glowing green, ensure that its bias adjustment potentiometer is turned fully counter-clockwise.

Note: If an output tube indicator lamp cannot be adjusted for both green and red, the associated output tube is probably faulty.

- 4) Adjust the bias potentiometer for each newly installed tube as follows:
 - a) Turn the potentiometer clockwise to a point where its lamp goes off (glows neither red nor green.)
 - b) Slowly turn the potentiometer counter-clockwise, again, to the point where its lamp just begins to glow fully green again. Repeat this step for each lamp as necessary until all four are glowing green.
- 5) After 10 minutes check the indicator lamps to see that they are still glowing green. For any lamp not glowing green, slowly turn its potentiometer counter-clockwise only until it glows green again.
- 6) Check every 30-45 minutes to ensure that the indicator lamps are still glowing green and adjust them if necessary.
- 7) After three hours, adjust each bias potentiometer to a position where its lamp does not glow (midway between red and green).

This completes the burn-in procedure for new output tubes. As future bias adjustments become necessary, use the Output Tube Bias Adjustment Procedure on page 9.

Tube Replacement

CAUTION: Before replacing tubes on your Stereo 80 ensure the AC power cord is unplugged from its AC (wall) outlet (or that the AC power cord is unplugged from the back of the unit) **and** wait for three minutes to allow the high voltage power supply to discharge. Gloves may be worn when changing tubes. Never touch live circuit elements in vacuum tube equipment because **lethal** voltages are present when these are turned on.

Note: There are no user serviceable parts inside the Stereo 80 chassis. If a problem arises other than normal periodic tube replacement, refer to your dealer or a qualified technician.

The most common type of problem in tube equipment is excessive noise caused by a worn or faulty tube. The characteristics of this noise can vary a great deal, such as: "excessive hiss," "sputtering," "rustling noises," etc. If a noise problem occurs with your Stereo 80, 99% of the time it will be due to a faulty tube. Vacuum tube equipment owners become familiar with tube noises and usually become less alarmed by them as time goes on.

Microphonics (various "pinging" or "howling" sounds) is due to a tube being overly sensitive to physical vibrations. To avoid this, do not operate vacuum tube equipment on top of vibrating surfaces (such as loudspeakers). But, if a tube is so sensitive that just having the amplifier turned on causes the microphonic sounds, the tube will have to be replaced. It can happen that a tube becomes microphonic with age or that it is only microphonic before it warms up (or only after it warms up).

Because it is possible for oxidation to build up on vacuum tube pins, it is a good idea to remove and clean them with a small (brass bristle) wire brush once a year. At this time it is also recommended to clean the tube pins with contact cleaner. Contact cleaner leaves a thin coating on the pins which helps prevent oxidation. The contact cleaner can either be sprayed directly onto the tube pins (don't get any on the glass part of the tube) or can be sprayed on a clean cloth which is then used to wipe the tube pins.

Notes: When removing a tube, grasp the tube socket with one hand and the tube with the other hand. Move the tube (slightly) from side to side while pulling upward.

An easy way to determine if a tube in any position is causing undesirable noise is to swap the suspected tube with its counterpart in the opposite channel. If the noise jumps to the other channel, the tube you suspected is indeed faulty.

The most certain method for confirming a faulty tube is by substitution of a known good tube.

Tube Replacement (cont.)

Input and Driver Tubes

The input and driver tubes in your Stereo 80 could provide 5,000 to 10,000 hours of use. They will probably outlast the output tubes by a factor of 2:1. We recommend that the input and driver tubes be replaced after no more than 3,000 to 4,000 hours of use to avoid the slightly "muffled" sound or slight bass "roll-off" which can begin to occur with old tubes. This replacement interval is equivalent to about 2 1/2 years when the amplifier is used 4 hours per day (or 5 years when used 2 hours per day).

The most likely source of tube noise in the Stereo 80 is the 12AT7 input tube - V1 (left channel) or V5 (right channel).

Output Tubes

You should expect the EL34s in the Stereo 80 to provide 3,000 to 4,000 hours of use before they have to be replaced. Some audiophiles replace them after as little as 1000 hours of use to keep the amplifier in top form. It is not uncommon, however, for an output tube to become faulty *during* its normal lifetime. The following conditions indicate possible output tube failure:

- An output tube will not bias properly - or refuses to hold its setting.
- The amplifier produces a somewhat "muffled" sound during use.
- The line fuse blows (other than from normal fuse fatigue).
- An output tube glows red during operation.
- Arcing is noticed inside the tube, upon close inspection.
- A tube filament will not light up.

Maximum performance of the Stereo 80 is achieved by using matched pairs of output tubes. The amplifier will work without matched output tube pairs, but may not fully meet all of the performance specifications. Matched pairs of output tubes are available from Dynaco or through your dealer.

Alternate Tube Types

It is true that vacuum tubes made by different manufactures can actually sound different. The amount and type of sonic differences can be subtle or fairly obvious to a discerning listener. Also, tube reliability and longevity often varies according to manufacturer.

Vacuum tube manufacturers are still introducing new versions of older tube designs. These new designs are commonly labeled with partly or wholly new part numbers. Furthermore, different vacuum tube manufacturers often use different part numbers for their own versions of “equivalent” tubes. Distributors sometimes substitute tubes from different manufacturers and/or substitute tubes with alternate part numbers *without informing their customers first*.

Some audiophiles feel strongly about which manufacturer and/or particular version of vacuum tube to use for specific applications. The tubes installed on your new Stereo 80 have been selected to provide the best sound and long life.

As of this writing, vacuum tubes are still produced by manufacturers in Germany (Siemens), Russia (Sovtek), Czechoslovakia (Telsa), China (Sino), Yugoslavia (EI), and in England. Your dealer can recommend U.S. tube distributors, if needed.

Alternate tube part numbers which can be used on the Stereo 80:

Designator	Common Part Numbers	Alternate Part Numbers
V1, V5	12AT7	ECC81
V2, V6	6DJ8	6922, ECC88, 7308
V3, V4, V7, V8	EL34	EL34G, 6CA7

If tube replacement becomes necessary, Dynaco can supply you with new tubes and/or a list of specifically recommended vacuum tubes for the Stereo 80.

Minimizing Noise in the System

Hum is caused by amplification of the 50 or 60 Hz AC power line signal that is transmitted via the magnetic fields around power transformers and power cables. RF interference usually comes from inadequate shielding of cables or components. If any of these types of noises are encountered, one or more of the following pointers concerning proper component positioning and grounding may be of use:

- Ensure that each system component, especially the preamplifier, is located far enough away from the other components so that they will not pick up hum from them, and that the AC power cables are not in close proximity to audio cables.
- Ensure that all audio cables are securely pushed into their respective jacks. A faulty audio cable, although rare, can be a source of hum if its outer shield is broken or disconnected from an RCA plug at one end of the cable.
- *The best system grounding scheme is to have your preamplifier well grounded to an earth ground point and function as the system's main ground reference. Other system components are then quite adequately grounded via their audio cables to the preamplifier's ground.* Using this grounding scheme can be as simple as just plugging the preamplifier's power cable into a three prong AC outlet. However, if the AC outlet itself does not provide a really "good" ground, the power cable can be plugged into a three-to-two prong adapter and a wire can be run from the tab on the adapter to the nearest cold water pipe.
- Another solution to AC power cable "ground loop" hum problems is to plug the AC power cables from all of the system components into a common "socket strip" (available from most hardware stores).
- If RF noise (usually an AM radio station or CB transmission) is a problem in your area, an AC power filter can be purchased into which some or all of your system power cords can be plugged. This is done if the RF is coming in through the building's AC wiring. However, if RF gets into the system via your turntable, you may have to use tonearm cables with better shielding. (This is tested by unplugging the turntable from the system and putting "shorting plugs" in the preamplifier's phono inputs before listening again.) RF noise is sometimes eliminated by simply moving the turntable or other components to another location in the room.
- Hum from a turntable is usually traced to an adjacent power transformer or a missing or improper ground. Check to see that the turntable motor is grounded via a wire to the preamplifier's grounding post - (or try removing this wire from the ground post if it is already connected there).

Warranty

For three years from the date of purchase (one year for tubes) Dynaco will repair, for the original owner, any defect in materials or workmanship that occurs in normal use, without charge for parts or labor.

It is the owner's responsibility to provide transportation to the authorized Dynaco service representative who will perform warranty service, and to present proof of purchase in the form of a dated sales slip when requesting service.

Excluded from this warranty is damage that results from abuse, misuse, accidents, shipping, or repairs or modification by anyone other than an authorized Dynaco service representative. This warranty is void if the serial number has been removed or defaced. This warranty gives you specific legal rights, and you may also have other rights - which vary from state to state.

If service is required, contact the dealer from whom you purchased the amplifier. If that is not possible, write Dynaco, giving us:

- ✓ Your name and address
- ✓ Make and model of your amplifier
- ✓ The amplifier's serial number
- ✓ When and where you purchased it (copy of sales slip)
- ✓ Description of the problem
- ✓ Whether you have the original carton and fillers or need new ones

DYNACO strongly recommends using only its performance checked pre-tested vacuum tubes. For best amplifier performance, matched pairs of power output tubes are available. Each tube is guaranteed to perform properly in its intended application for ONE YEAR. Orders for tubes may be paid for by personal check or money order. Please also include \$4.00 for shipping and handling.

Stereo 80 Specifications

POWER OUTPUT	40W per channel into 2, 4, or 8 ohms
POWER BANDWIDTH:	40W from 17Hz to 75kHz (-3dB points)
THD	< 1% @ full power @ 1kHz < .05% @ 1W @ 1kHz, matched output tubes
FREQUENCY RESPONSE	2Hz to 60kHz (-3dB points)
INPUT SENSITIVITY	.3V for full power output (Input Sensitivity Control set to maximum)
INPUT IMPEDANCE	50k
SLEW RATE	30V/ μ S
SIGNAL-TO-NOISE RATIO	90db below full output
TUBE COMPLEMENT	two 12AT7, two 6DJ8, four EL34
<hr/>	
POWER CONSUMPTION:	210 Watts
AC LINE VOLTAGE	100V, 120V, 220V, or 240V @ 50/60 Hz
<hr/>	
DIMENSIONS	17" Wide, 7.75" High, 15" Deep
SHIPPING WEIGHT	42 lbs
<hr/>	
WARRANTY	Three years - parts and labor. (one year on tubes)

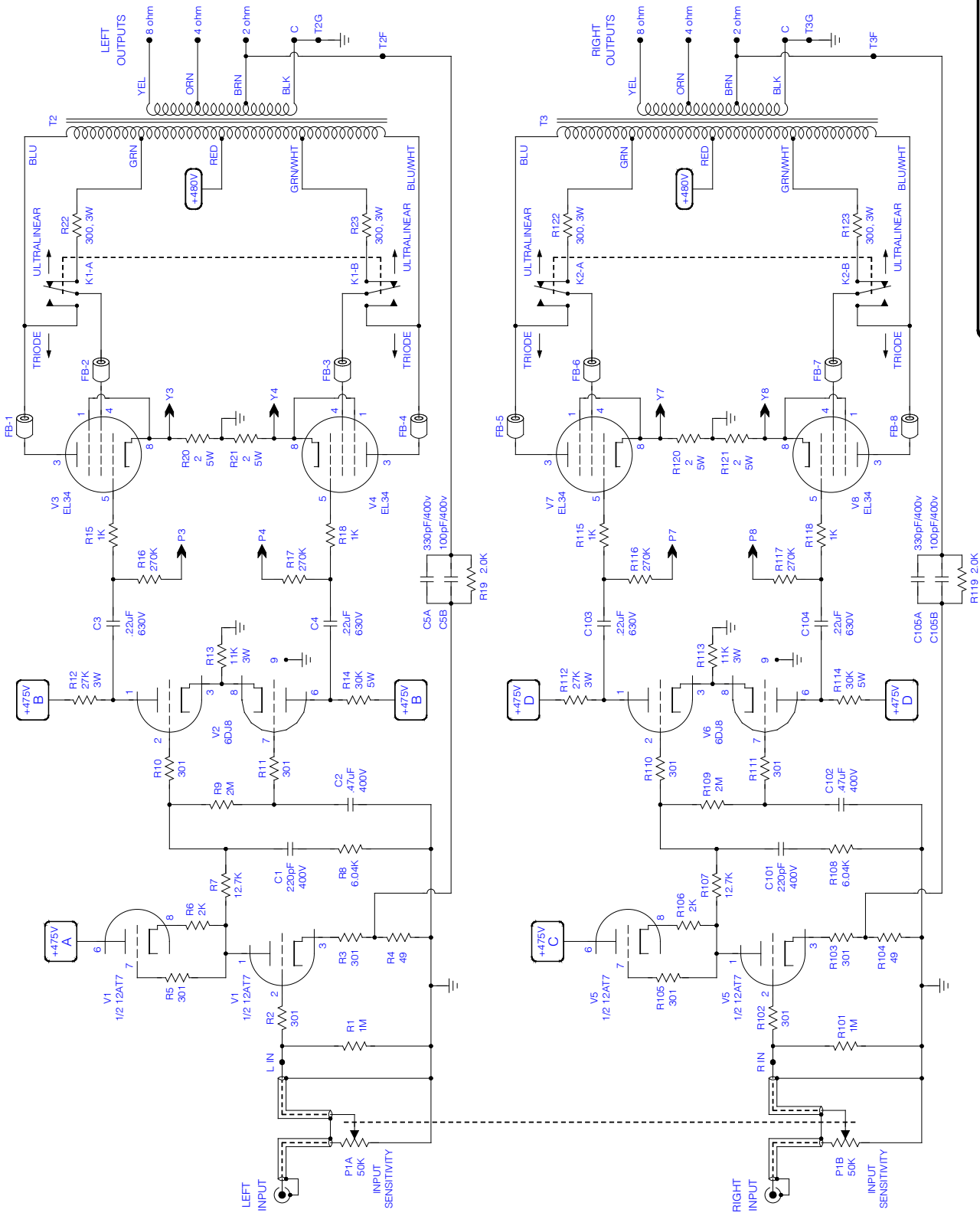

1/2W AND 1W RESISTORS ARE METAL FILM
3W AND 5W RESISTORS ARE METAL OXIDE

dynaco

STEREO 80 AUDIO SECTION

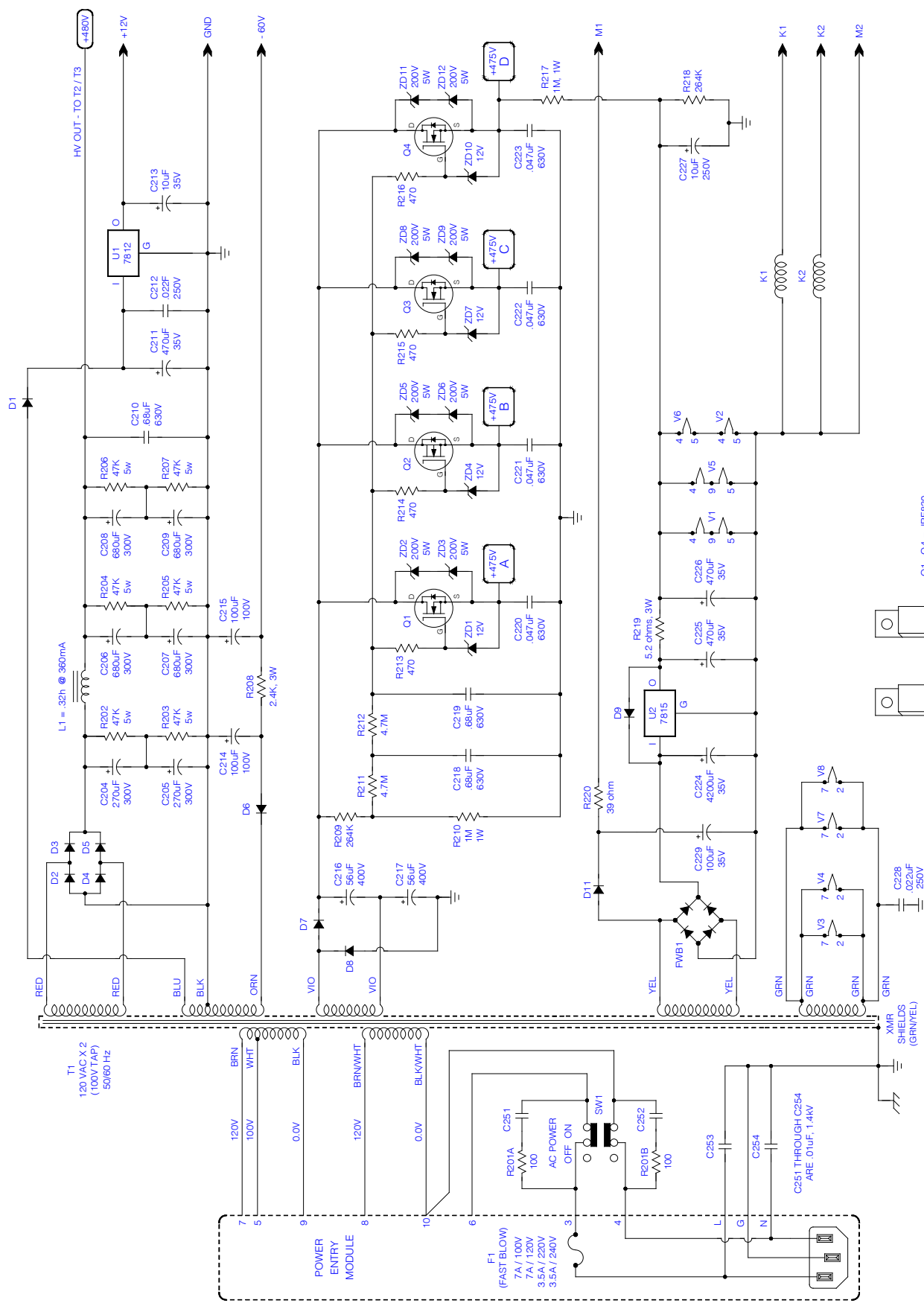

- O1 - O4 = IRF830
- D1 - D11 = 2.5A, 1KV
- ZD1, 4, 7, 10 = 1N5242B
- ZD2, 3, 5, 6, 8, 9, 11, 12 = 1N5388B

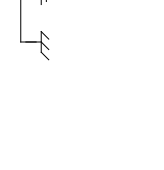
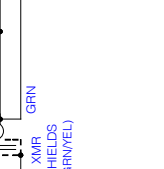
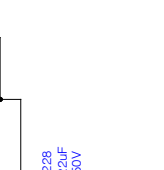
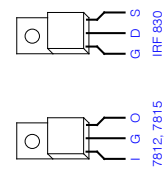

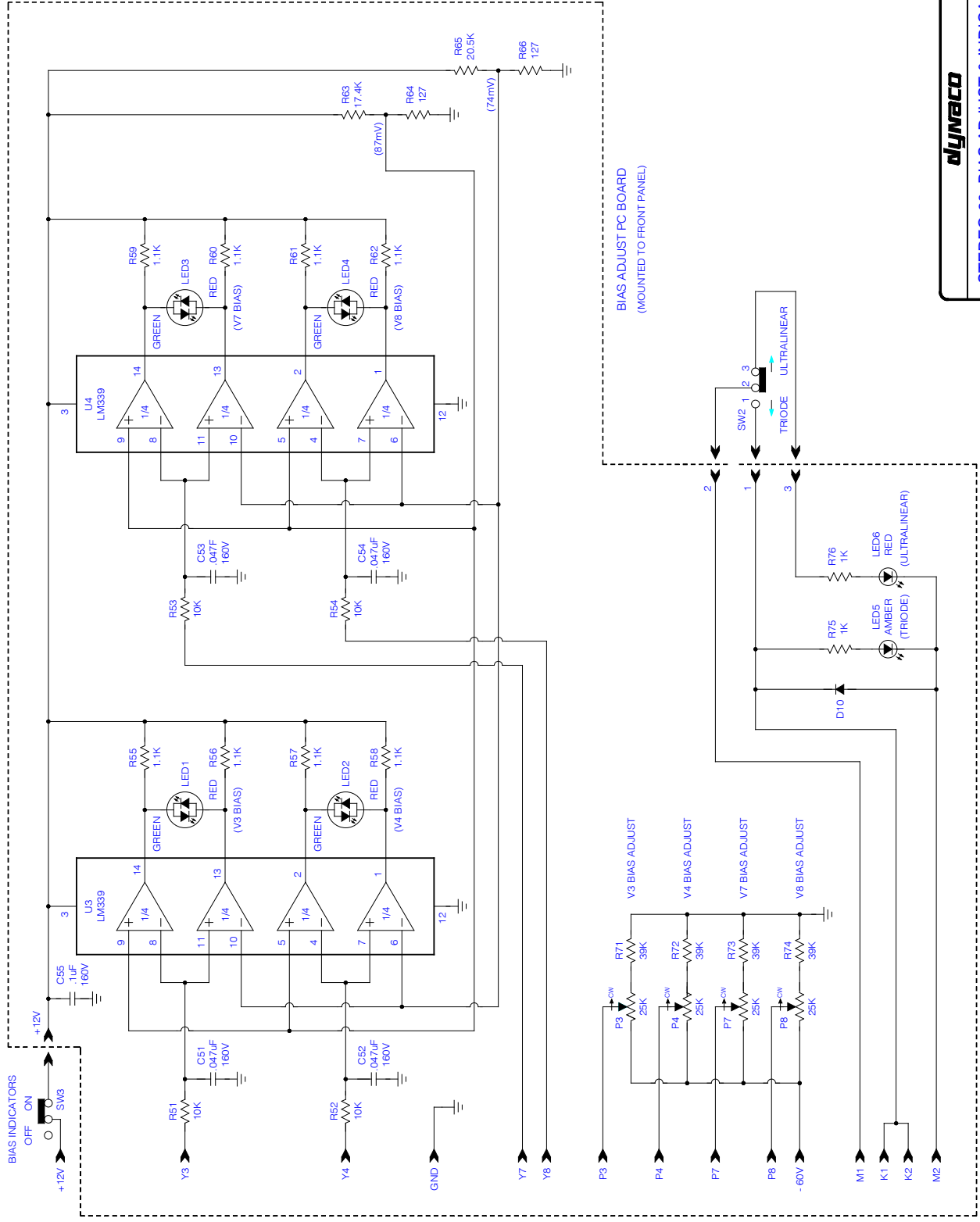

BIAS ADJUST PC BOARD
(MOUNTED TO FRONT PANEL)



Stereo 80 PC Board Parts List

<i>Resistors</i>	
39 ohm, 1/2W, metal film	R220
49 ohm, 1/2W, metal film	R4, 104
100 ohm, 1/2W, metal film	R201A, 201B
127 ohm, 1/2W, metal film	R64, 66
301 ohm, 1/2W, metal film	R2, 3, 5, 10, 11, 102, 103, 105, 110, 111
470 ohm, 1/2W, metal film	R213, 214, 215, 216
1K, 1/2W, metal film	R15, 18, 75, 76, 115, 118
1.1K, 1/2W, metal film	R55, 56, 57, 58, 59, 60, 61, 62
2K, 1/2W, metal film	R6, R19, 106, 119
6.04K, 1/2W, metal film	R8, 108
10K, 1/2W, metal film	R51, 52, 53, 54
12.7K, 1/2W, metal film	R7, 107
17.4K, 1/2W, metal film	R63
20.5K, 1/2W, metal film	R65
39K, 1/2W, metal film	R71, 72, 73, 74
264K, 1/2W, metal film	R209, 218
270K, 1/2W, metal film	R16, 17, 116, 117
1Meg, 1/2W, metal film	R1, 101
2 Meg, 1/2W, metal film	R9, 109
4.7Meg, 1/2W, metal film	R211, 212
1 Meg, 1W, metal film	R210, 217
5.2 ohm, 3W, metal oxide	R219
300 ohm, 3W, metal oxide	R22, 23, 122, 123
2.4K, 3W, metal oxide	R208
11K, 3W, metal oxide	R13, 113
27K, 3W, metal oxide	R12, 112
30K, 3W, metal oxide	R14, 114
2 ohm, 5W, metal oxide	R20, 21, 120, 121
47K, 5W, metal oxide	R202, 203, 204, 205, 206, 207
Dual Potentiometer - 50K audio taper	P1
Trimmer Potentiometer - 25K	P3, 4, 7, 8
<i>Capacitors</i>	
.01uF, 1.4kV, ceramic disk	C251, 252, 253, 254
100pF, 400V, polypropylene, 5%	C5B, C105B
220pF, 400V, polypropylene, 5%	C1, 101
330pF, 400V, polypropylene, 5%	C5A, 105A
.022uF, 250V, polypropylene, 10%	C212, 228
.047uF, 160V, polypropylene, 10%	C51, 52, 53, 54
.047uF, 630V, polypropylene, 10%	C220, 221, 222, 223
.1uF, 160V, polypropylene, 10%	C55
.22uF, 630V, polypropylene, 10%	C3, 4, 103, 104
.47uF, 400V, polypropylene, 10%	C2, 102
.68uF, 630V, polypropylene, 10%	C210, 218, 219
10uF, 35V, alum electrolytic	C213
10uF, 250V, alum electrolytic	C227
56uF, 400V, aluminum electrolytic	C216, 217
100uF, 35V, alum electrolytic	C229
100uF, 100V, alum electrolytic	C214, 215
270uF, 300V, alum electrolytic	C204, 205
470uF, 35V, alum electrolytic	C211, 225, 226
680uF, 300V, alum electrolytic	C206, 207, 208, 209
4200uF, 35V, alum electrolytic	C224

Stereo 80 PC Board Parts List (cont.)

<i>Semiconductors</i>	
2.5A, 1KV	D1 through D11
1N5242B (12V, 1/2W Zener)	ZD1, 4, 7, 10
1N 5388 (200V, 5W Zener)	ZD2, 3, 5, 6, 8, 9, 11, 12
3506 (35A, 600V Bridge Rectifier)	FWB1
IRF 830 (N-channel FET)	Q1, 2, 3, 4
7812 (TO-220) [LM78M12CT]	U1
7815 (TO-220) [LM78M15CT]	U2
LED (red, T-1 3/4 type)	LED5, 6
LED, 2-color (2-term, T-1 3/4 type)	LED1, 2, 3, 4
LM339 (Quad Comparator)	U3, 4
<i>Tubes</i>	
Tube, 12AT7	V1, 5
Tube, 6DJ8	V2, 6
Tube, EL34	V3, 4, 7, 8
<i>Misc.</i>	
Tube Socket - 9-pin, PCB mount	for V1, 2, 5, 6
Tube Socket - 8-pin, PCB mount	for V3, 4, 7, 8
Switch, DPST, (AC Power)	SW1
Switch, SPDT, (Triode/Ultralinear)	SW2
Switch, SPST, (Bias Lamps)	SW3
Relay, 12V, DPDT	K1, 2
Ferrite Beads	FB1 through FB8
Choke, .32 henry @ 360ma	L1
Fuse, 7A fast-blow (100 and 120VAC) 3.5A fast-blow (220 and 240VAC)	F1 (in power entry module)
Heat Sink - Thermalloy P/N 7019B-MT	HS-1 through HS6
Heat Sink - Thermalloy P/N 7025B-MT	HS7, 8
Heat Sink - for U1	HS9
Power Transformer	T1
Output Transformer	T2, 3
Audio PC Board	Dynaco P/N 17-0421-P
Bias Light PC Board	Dynaco P/N 17-0422-P
Input PC Board	Dynaco P/N 17-0459

Dynaco

A Division of Panor Corporation
125 Cabot Court
Hauppauge, New York 11788

(516) 434-1200
(516) 434-1457 FAX